

TECHNICAL SPECIFICATIONS

Product Code: 580074

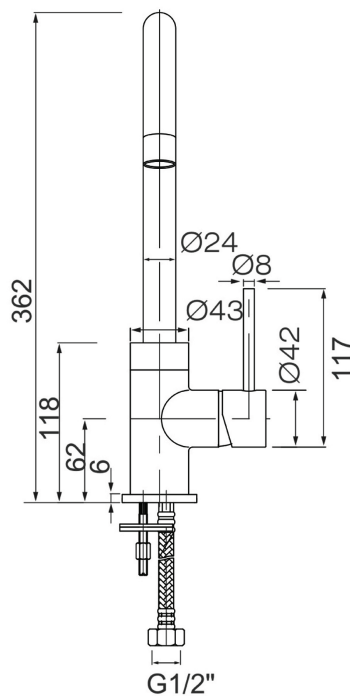

Description	SF074 Sink Mixer
Box Qty	8
Pressure System	Single Flow
Head	Ceramic Disc Valve
Inlet	1/2" Flexi Hoses
Outlet	Aerator - Air Aerator
Min/Max Operating Pressure	0.5 - 5 BAR

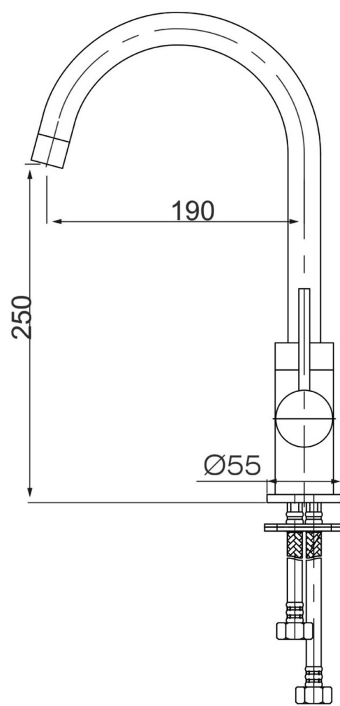

Sanbra Fyffe Ltd, CONEX Works Santry Ave, Dublin 9

Tel: 01 842 6255 Fax: 01 842 6134

sales@sanbra.ie www.sanbra.ie